

Classifying subfactors up to index 5

Emily Peters

<http://euclid.unh.edu/~eep>

Noah Snyder

<http://math.columbia.edu/~nsnyder>

joint work with F. Calegari, Jones, Morrison, Penneys

Shanks Workshop on Subfactors and Tensor Categories

<http://euclid.unh.edu/~eep/Shanks2010.pdf>

Outline

Outline

Principal graphs up to index $3 + \sqrt{3}$

Theorem (Haagerup, Asaeda-Haagerup, Bisch, Asaeda-Yasuda, Bigelow-Morrison-Peters-Snyder)

There are only three principal graphs with index in the range

$(4, 3 + \sqrt{3})$:



Our goal: Principal graphs up to 5

Theorem (Haagerup, Asaeda-Haagerup, Bisch, Asaeda, Asaeda-Yasuda, Bigelow-Morrison-Peters-Snyder)

There are exactly three subfactors with index in the range $(4, 3 + \sqrt{3})$. Their principal graphs are:



Conjecture (Goodman-de la Harpe-Jones, Izumi, Xu, work in progress of Calegari, Jones, Morrison, Penneys, Peters, Snyder)

There are only two subfactors in the range $[3 + \sqrt{3}, 5)$. Their principal graphs are:

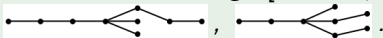

Broad outline of argument

As with Haagerup's initial argument we first run the "Haagerup odometer" to get a list of potential families of principal graphs, and then apply other tests to eliminate families.

Running the odometer yields something like:

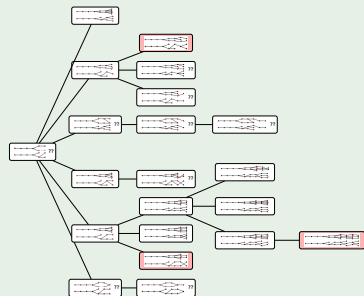

(Don't worry! This will be explained in detail below.)

Principal graphs with dual data

What are the individual entries in that giant picture?

They're a pair of graphs with dual data. But where only the parity of the supertransitivity has been specified.

Side note

We can assume that they're not 1ST by a different argument.

Example: The Haagerup family

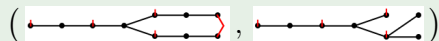

The duals of odd objects are specified by the vertical ordering. The duals of even objects are specified by the red lines.

Graphs with dual data and Ocneanu-style graphs

Ocneanu-style 4-partite graphs

$$\begin{array}{ccc} A \bmod B & \xrightarrow{B \otimes_A} & B \bmod B \\ \uparrow \otimes_A B & & \uparrow \otimes_A B \\ A \bmod A & \xrightarrow{B \otimes_A} & B \bmod A \end{array}$$

Reconstructing the Ocneanu graph from graphs with dual data

$(X \otimes Y)^* = Y^* \otimes X^*$, so if you understand tensoring on one side the dual data lets you figure out tensoring on the other side.

Example

Pair of graphs with dual data

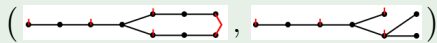

Corresponding Ocneanu graph (top = bottom)



Outline

Enumerating possible principal graphs

The odometer takes a graph pair with dual data, and looks at all ways to extend both graphs by one depth so that

- The index stays below a given limit
- The new graph passes certain tests.

Example

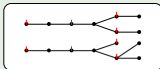

Enumerating possible principal graphs

The odometer takes a graph pair with dual data, and looks at all ways to extend both graphs by one depth so that

- The index stays below a given limit
- The new graph passes certain tests.

Example



Enumerating possible principal graphs

The odometer takes a graph pair with dual data, and looks at all ways to extend both graphs by one depth so that

- The index stays below a given limit
- The new graph passes certain tests.

Example

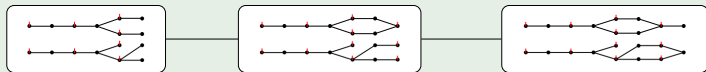

Enumerating possible principal graphs

The odometer takes a graph pair with dual data, and looks at all ways to extend both graphs by one depth so that

- The index stays below a given limit
- The new graph passes certain tests.

Example

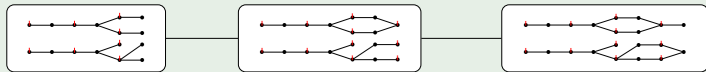

Warning!

Once you've run the odometer you still need to look for graphs where you extend only one of the two graphs. For example, Haagerup comes up by extending only the principal graph in the first pair above.

Terminology: Weeds and Vines

Definition

- A translate of a graph is a new graph produced by increasing the supertransitivity by adding a string of vertices on the left.
- An extension of a graph is a new graph produced by adding anything you want to the right of the graph.

Definition

- The vines \mathcal{V} is a finite set of graphs, any translate of which might be a principal graph.
- The weeds \mathcal{W} is a finite set of graphs, any extension of a translate of which might be a principal graph.

Example

Haagerup's classification has no weeds, and only three vines.

What the odometer does to weeds and vines

Step 1

We start with $\mathcal{V} = \emptyset$ and $\mathcal{W} = \{ \bullet \rightarrow \bullet \}$.

Step 2

Take a graph from \mathcal{W} , move it to \mathcal{V} , and add to \mathcal{W} all of its extensions to one further depth that remain below the index limit.

Repeat Step 2

When to stop?

We hope to keep doing this until we empty \mathcal{W} . This worked for Haagerup. It won't quite work for us.

Tests that apply to all weeds

The Ocneanu triple point obstruction

An initial triple point “can’t be too boring.” (Proof uses unitarity of a certain 3-by-3 matrix.)

The square test

Associativity tells you that there has to be the same number of length 2 paths going one way around the Ocneanu square as going the other way. For weeds you can apply this to pairs of vertices that aren’t at the deepest depth.

These two tests complement each other nicely, as the easy ways to pass the square test fails the triple point obstructions.

Running the odometer on 10-excess graphs

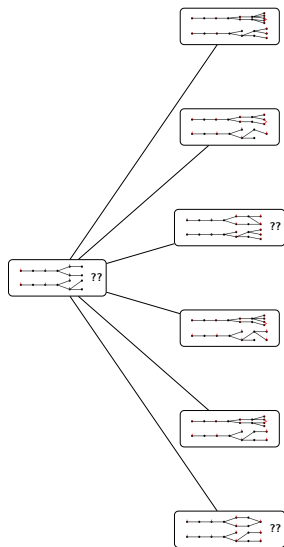

Running the odometer on 10-excess graphs

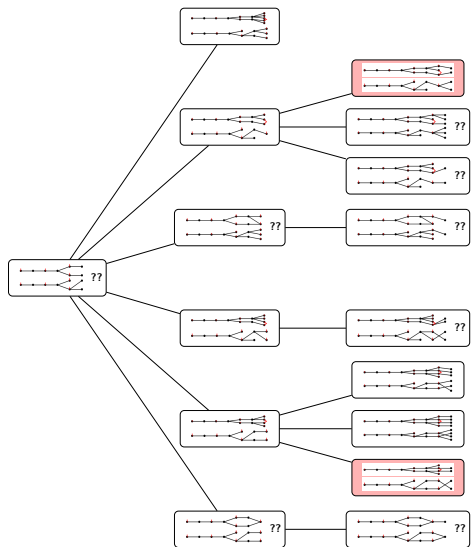

Running the odometer on 10-excess graphs

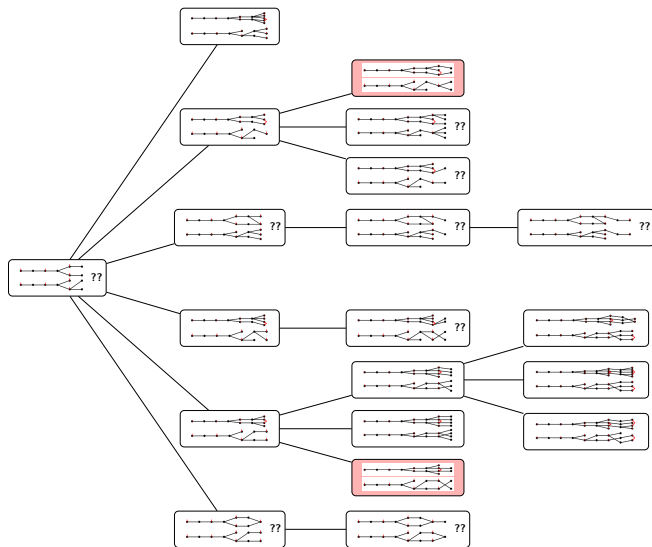

Running the odometer on 10-excess graphs

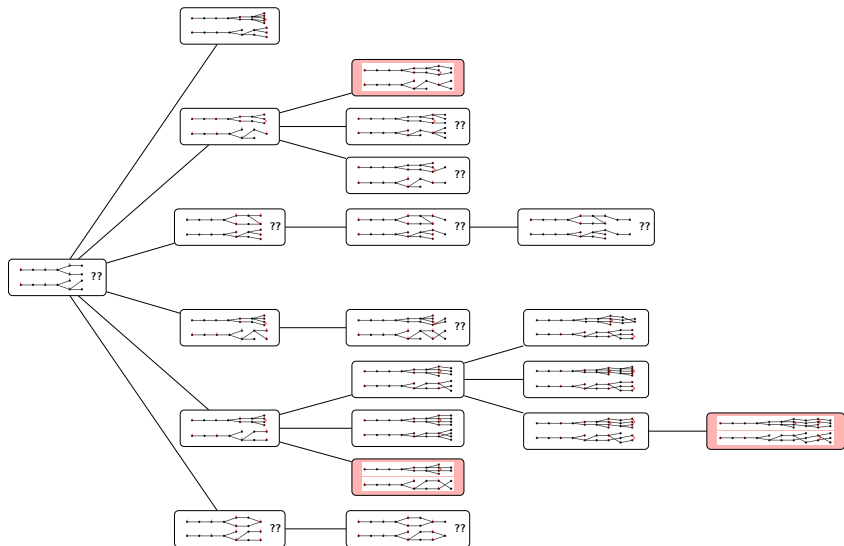

Outline

The Quadratic Tangles attack!

This attack kills many vines and also some weeds.

Theorem (Jones)

If Γ is nST , has excess 10, has r as the ratio of dimensions past the split, and ω is the rotational eigenvalue, then:

$$r + \frac{1}{r} = 2 + \frac{2 + \omega + \omega^{-1}}{[n][n+2]}.$$

Corollary

$$(r + r^{-1} - 2)[n][n+2] - 2 \in [-2, 2]$$

Quadratic Tangles attack

Awesome things

This lets us kill off many vines using QT. It also lets us kill off some weeds too! Some version of it should work for vines with excess 11.

Sad things

This test is useless when $r = 1$. This was a big problem for Haagerup as most of his vines had $r = 1$. Most of our new vines do not have $r = 1$. But there is a weed with $r = 1$.

Number theory attack

This attack kills any vine! But it is useless for weeds.

Theorem (Etingof-Nikshych-Ostrik)

If \mathcal{C} is a fusion category, $f : K(\mathcal{C}) \rightarrow \mathbb{C}$ is a “dimension function,” and $X \in \text{Obj}(\mathcal{C})$, then $f([X])$ is an algebraic integer in a cyclotomic number field.

Corollary

If x is the index of a finite depth subfactor then x is a cyclotomic integer.

Corollary

If λ is a multiplicity one eigenvalue of the adjacency matrix of a principal graph of a finite depth subfactor, then λ^2 is cyclotomic integer.

Theorem (Asaeda, Asaeda-Yasuda)

Except for Haagerup and extended Haagerup, none of the graphs in the Haagerup family have cyclotomic indices.

Theorem (Calegari-Morrison-Snyder, Cassels, Loxton)

For any family Γ_n coming from a fixed vine Γ , there's an integer N such that for all $n > N$ the index of Γ_n is not cyclotomic.

Theorem (Calegari-Morrison-Snyder, Cassels)

For any family Γ_n coming from a fixed vine Γ , there's an effectively computable integer N such that for all $n > N$ there's a multiplicity one eigenvalue λ_n such that λ_n^2 is not cyclotomic.

The cases we're stuck on

Odd quadruple point

Translations of extensions of



'The bad seed'

Translations of extensions of



We hope that QT will eventually work for the former. We're genuinely stuck on the latter.

So, maybe these give new subfactors ...?

We've ruled out any translations/extensions of these which involve fewer than ≈ 45 vertices (the bad seed) or ≈ 20 vertices (the quadruple point).

Relationship between subfactors and objects in UTCs

- If A is a Frobenius algebra object in a unitary tensor category \mathcal{C} , then it comes from a subfactor of index $\dim A$.
- If X is an object in \mathcal{C} , then $X \otimes X^*$ is a Frobenius algebra object.
- In particular, if there's an object X in a UTC of dimension d then there must be a corresponding subfactor of index d^2 .
- I think the converse holds: if there's a subfactor of index d^2 then it always comes from an object in a UTC.

Say that again in pictures

A unitary tensor category is the same thing as an oriented planar algebra. You can get a shaded planar algebra by looking at the “alternating part.”

What about objects in fusion categories?

We could try applying the classification above. But we can do better using number theory.

Theorem (Calegari-Morrison-Snyder)

Let X be an object in a fusion category with Frobenius–Perron dimension > 2 . Then either $\dim(X) \geq 76/33 = 2.303030\dots$ or $\dim(X)$ is equal to one of the following algebraic integers:

$$(\sqrt{7} + \sqrt{3})/2 = 2.188901059\dots$$

$$\sqrt{5} = 2.236067977\dots$$

$$1 + 2 \cos(2\pi/7) = 2.246979603\dots$$

$$(1 + \sqrt{5})/\sqrt{2} = 2.288245611\dots$$

$$\frac{1 + \sqrt{13}}{2} = 2.302775637\dots$$

Proof.

If X is the Frobenius-Perron dimension of an object in a fusion category then it is:

- A cyclotomic integer,
- real,
- maximal among its Galois conjugates.

The above list is all the numbers satisfying these properties. \square

Open Question

Is there a real cyclotomic integer which is maximal among its Galois conjugates but is not the dimension of an object?